

# Elastic Networks Employs Magnum P62F Hardened Ethernet Switches to Deploy DSL Internet Access to Outlying Users

## Broadband Communications

### TECHNOLOGY TODAY

DSL is a popular technology for providing affordable high-speed Internet access to homes and small businesses. However, it has some limitations that are impacting the speed of deployment. For example, DSL requires that the customer be within 18,000 feet or less of a telecommunications service provider's central office. DSL is also susceptible to interference, which can impact performance.

Innovative companies are finding ways to extend the range of DSL, and 100Mbps Ethernet switches running single-mode fiber cabling are a proven part of the solution.

### ABOUT ELASTIC NETWORKS

Elastic Networks™ based in Alpharetta, Georgia, provides innovative, next-generation DSL technology and high-speed Internet access solutions. It enables telecommunications service providers to offer affordable broadband services that simplify the way people connect. The company is bringing DSL capability to areas where older technology was not cost effective.

### THE CHALLENGE

Elastic Networks uses a patented EtherLoop™ technology to provide high-speed first-mile solutions that can run on existing copper lines to lower cost and provide higher quality of service.

Elastic Networks uses DSLAMs (Digital Subscriber Line Access Multiplexers) in remote cabinets to bring broadband service to outlying areas. The initial design included T1 bridges. T1 lines, however, required a hubbed configuration that was very expensive because it involved the laying of considerable amount of cabling. The company hoped to identify a high-bandwidth, reliable solution that would allow daisy-chaining of 100Mbps Ethernet switches using single-mode fiber between the DSLAMs to reduce cabling costs. In addition, the selected equipment had to operate reliably in all weather conditions.

Elastic Networks turned to ZCorum, a system integrator based in Alpharetta, Georgia, which offers end-to-end broadband Internet and communications solutions to telephone companies, utilities, ISPs, municipalities, and other organizations with complex data management needs.

### THE SOLUTION

ZCorum worked with Elastic Networks to identify a solution using daisy-chained Fast Ethernet transport. Fast Ethernet provides faster throughput at lower cost than a T1 bridge solution at distances of up to 20Km.

Because it would be installed outdoors, the Fast Ethernet switch had to withstand harsh conditions and extended operating temperature ranges. To meet the requirements of the remote cabinets, the switch needed to be small and robust, and operate using the telephone companies' traditional -48VDC power.

ZCorum and Elastic Networks initially looked to custom solutions. However, after reviewing the specifications of the Magnum P62F Ethernet Switch, they found a highly reliable off-the-shelf solution that met their needs perfectly (see Diagram 1).

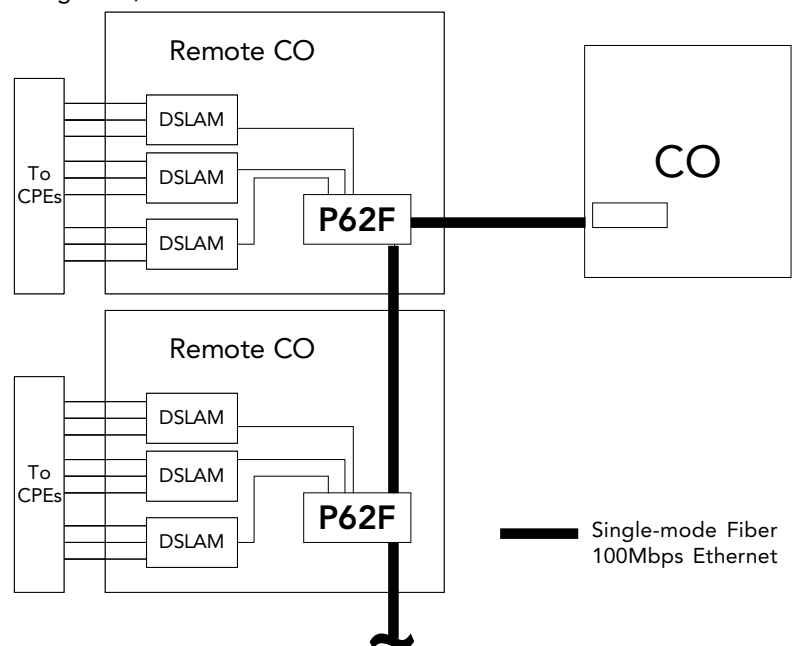

Diagram 1. Elastic Networks uses Magnum P62F Switches in its network.

## Ethernet Outdoors

### Elastic Networks

#### THE RESULT

Elastic Networks has deployed a fiber-based DSL network using Fast Ethernet capabilities provided by the Magnum P62F Ethernet Switch in new installations for the outside plant. Using single-mode fiber between remote Central Offices (COs), Elastic Networks has a range of up to 20Km between remote CO installations. Within a remote CO, Elastic Networks uses the Magnum P62F copper ports to link to DSL multiplexers, which then link to CPEs (Customer Premises Equipment).

The Magnum P62F Ethernet Switch offers numerous benefits, including:

- Built-in single-mode fiber ports that support easy installation of daisy-chained connections in the field;
- Built-for-reliability design that meets the requirements for telephone equipment (15 years MTBF);
- Compact 1.7" x 5.75" x 9" packaging;
- Ambient temperature rating of -40° to 160°F to withstand harsh weather conditions;
- Higher performance and significant cost savings compared with T1 lines or other protocols

#### ABOUT THE MAGNUM P62F SWITCH

The Magnum P62F Ethernet Switch is specifically designed to operate in industrial and outdoors environments. Its case is engineered as a heat sink, which allows the switch to be deployed in environments where temperatures can extend far beyond the range of human comfort.

It has six 10/100Mb switched RJ-45 ports and two 100Mb fiber ports that allow daisy-chained configurations of the P62Fs to be deployed over long distances (see Diagram 2).

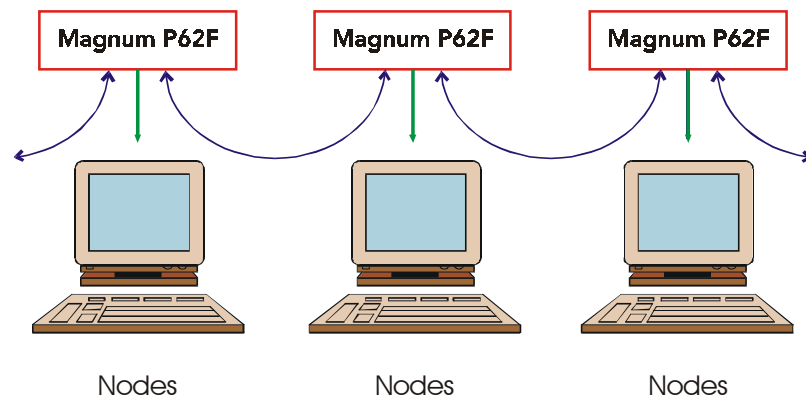

Diagram 2. The fiber ports in Magnum P62F can be used to daisy-chain multiple units and enable non-traditional Ethernet applications.

#### ABOUT GARRETTCOM

GarrettCom is the leading supplier of Industrial and Carrier-Class Ethernet LAN products. GarrettCom designs, manufactures and markets a comprehensive line of ETSI and NEBS-Certified switches and hubs for use in telecommunications systems, industrial, and automation environments worldwide. For more information on GarrettCom and its products, visit [www.GarrettCom.com](http://www.GarrettCom.com).

© 2001 GarrettCom, Inc. GarrettCom, Magnum, and Personal Switch are a trademarks and Personal Hub is a registered trademark of GarrettCom, Inc. NEBS is a trademark of Telcordia Technologies. Ethernet is a trademark of Xerox Corporation. All other products and/or company names are trademarks of their respective owners. Rev.10/01.



GarrettCom, Inc.

213 Hammond Ave. • Fremont, CA 94539 • PH: (510) 438-9071 • FAX (510) 438-9072  
Email: [mktg@garrettcom.com](mailto:mktg@garrettcom.com) • Web: [www.GarrettCom.com](http://www.GarrettCom.com)